



Figure 1

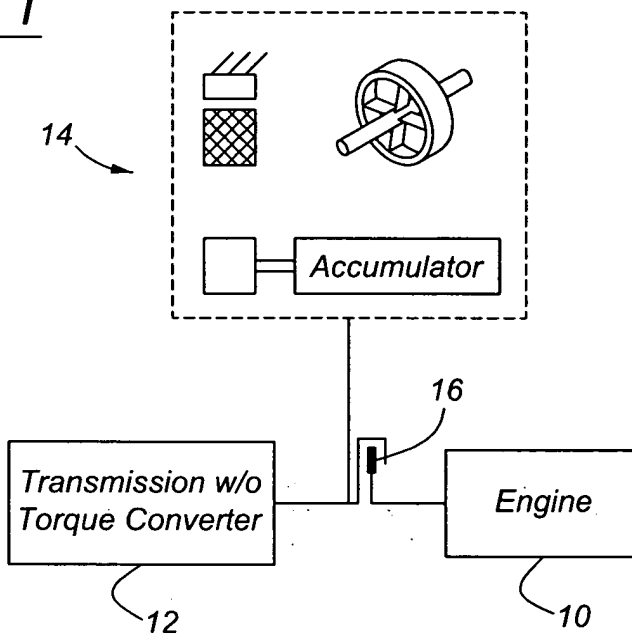
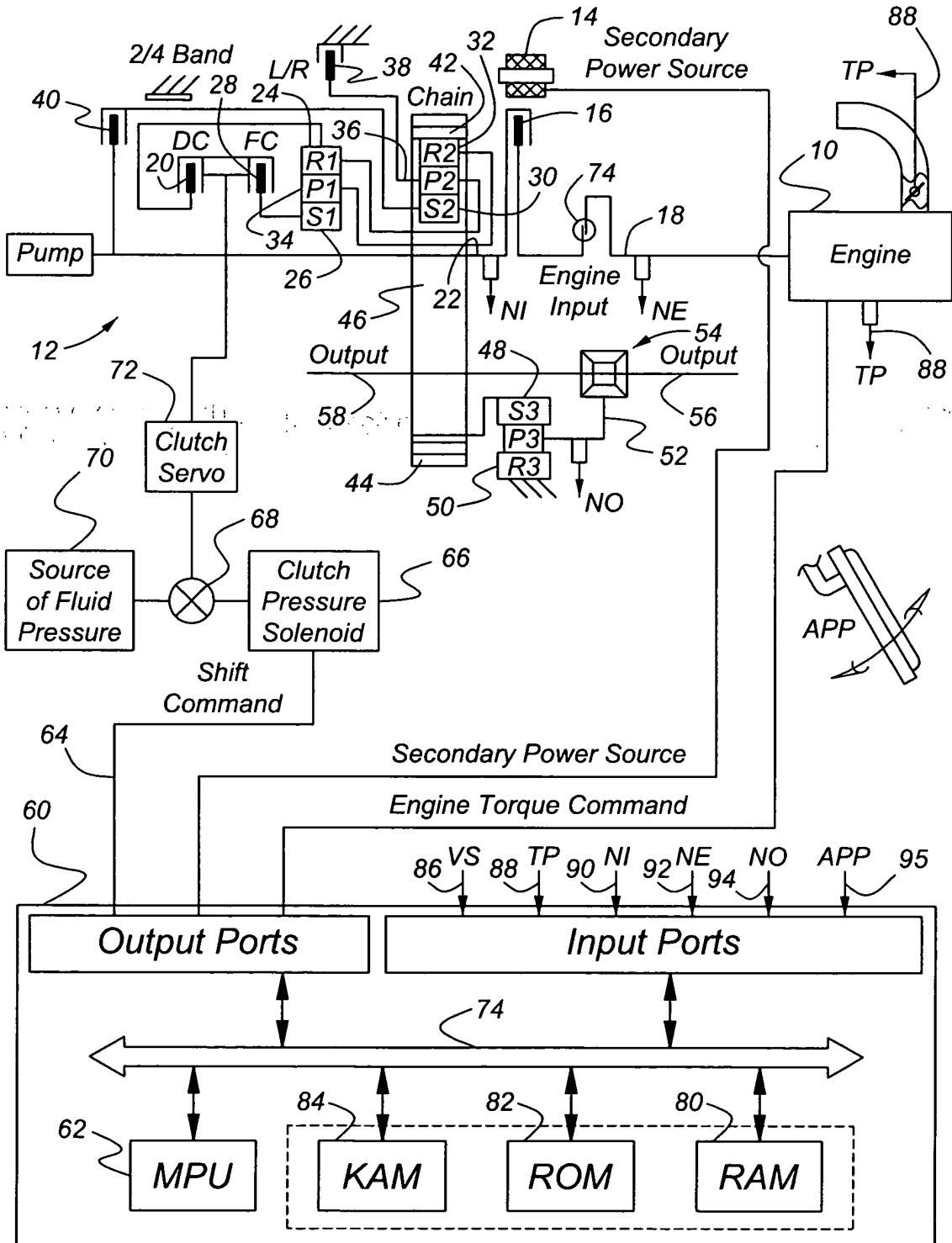

Figure 3

Gear	40	28	20	38	2/4 Band
1st		X		X	
2nd		X			X
3rd		X	X		
4th			X		X
REV	X			X	

Figure 2



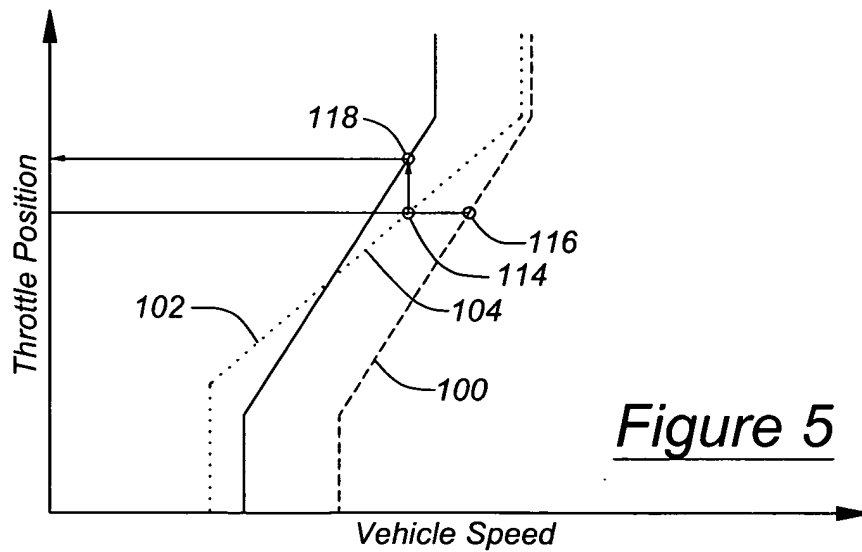
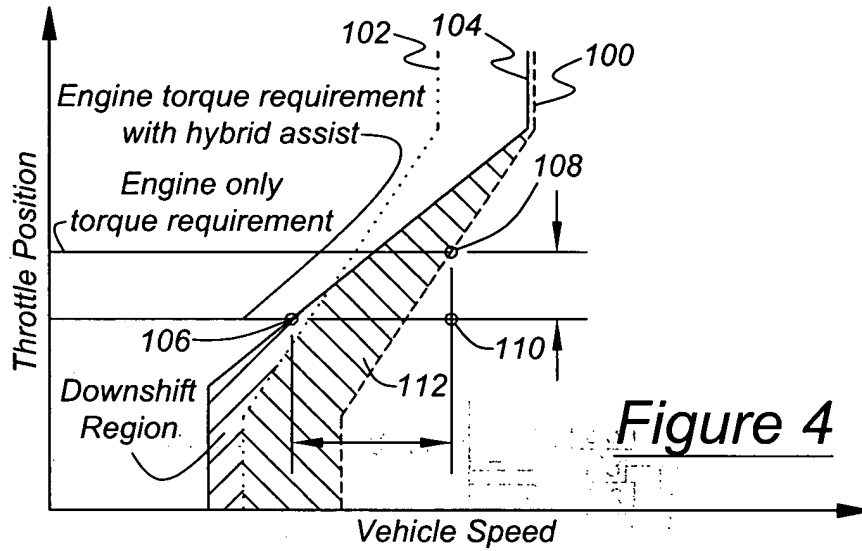

Figure 6

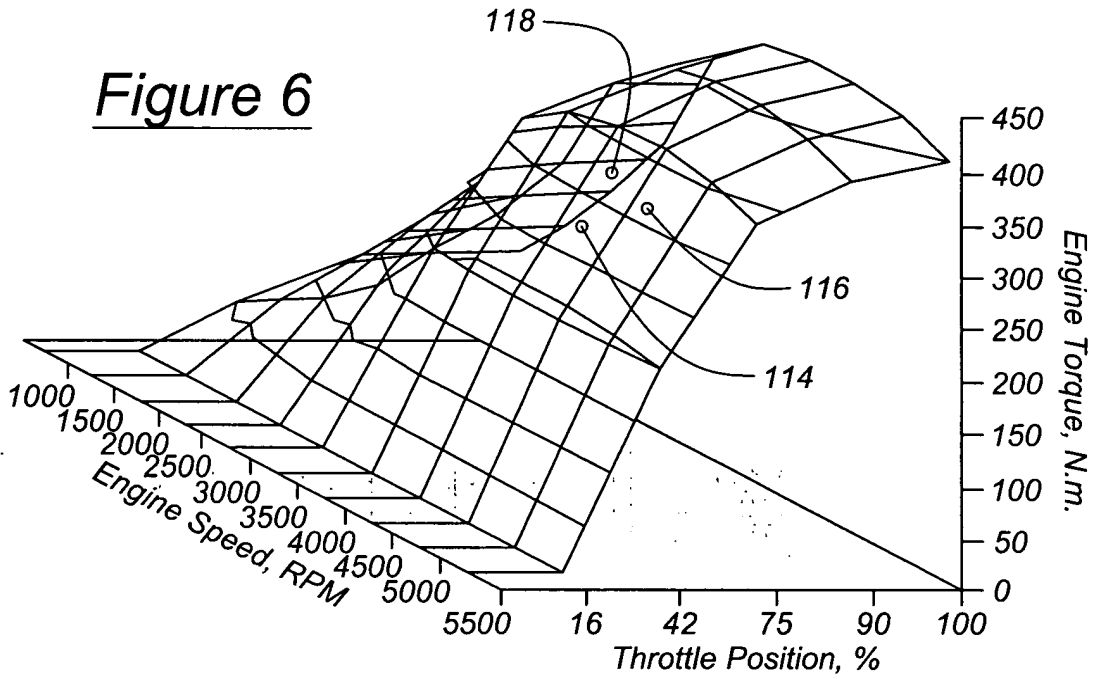
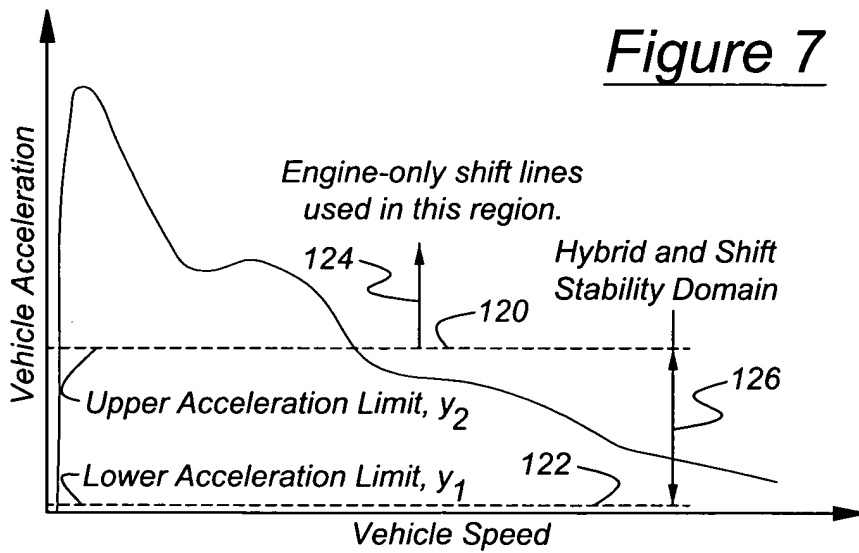

Figure 7



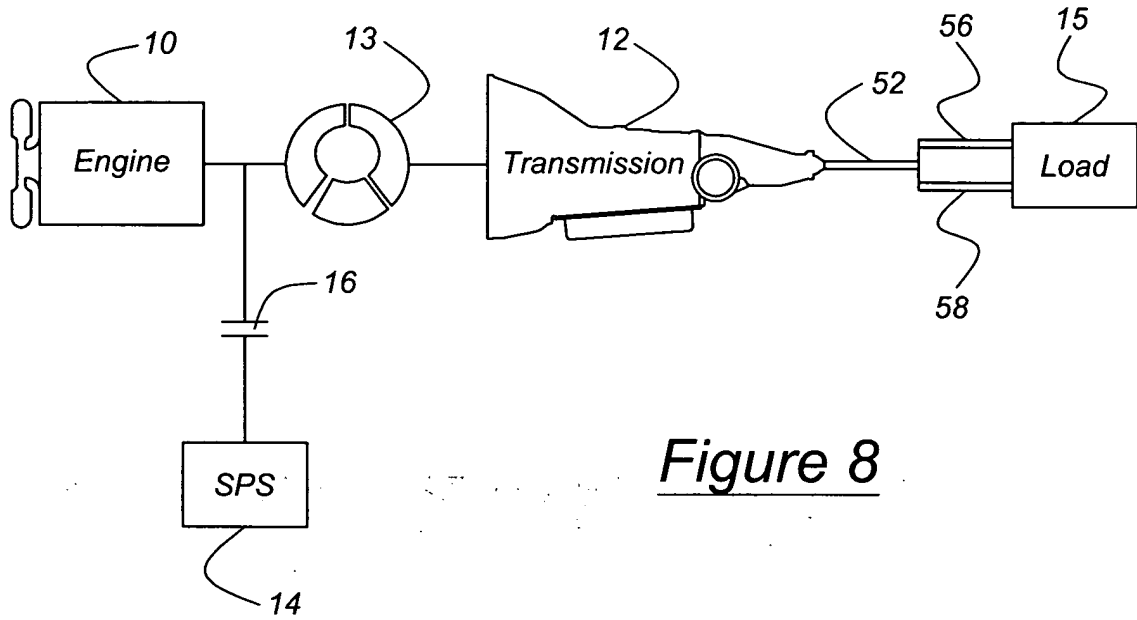

Figure 8

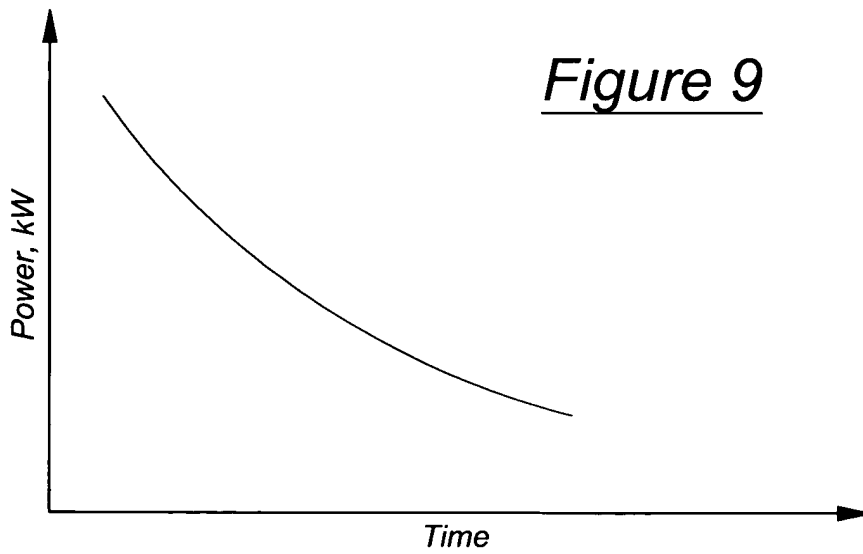

Figure 9